

REVISIONS					
REV	DESCRIPTION	DRN	CHK	APPD	DATE
REV 04					

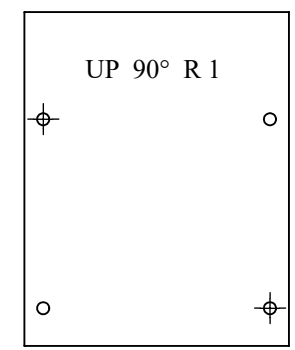
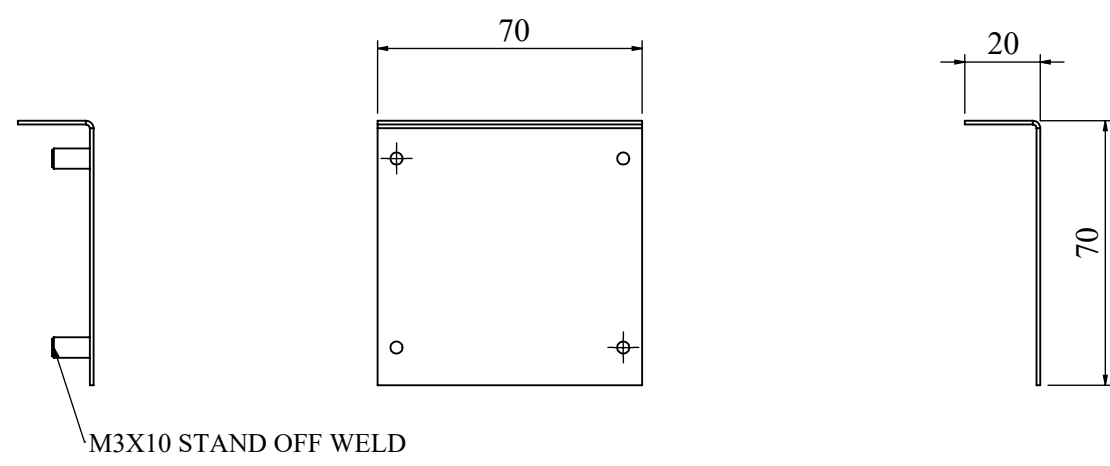
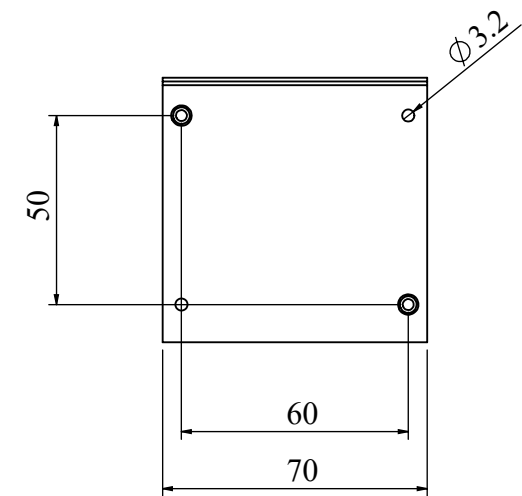
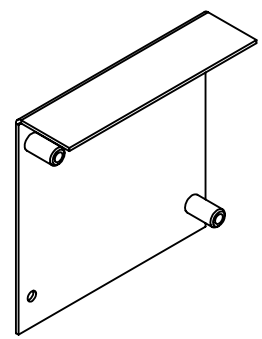

ITEM NO.	PARTNO	DESCRIPTION	QTY.
1	RCAB00976R0-01-09_01	SPIKE PLATE	1
2	RCAB00976R0-02_04	M3X10 STAND OFF(RIVET)	2

NOTES - UNLESS OTHERWISE SPECIFIED:

1. FINISH: POWDER COATED - 7016 - ANTHRACITE GREY (TEXTURE)
2. DIMENSIONS ARE TO BE INTERPRETED AS PER ASME Y14.5M - 1994.
3. ALL DIMENSIONS APPLY AFTER FINISHING.
4. PART TO BE CLEAN AND FREE OF ALL SHARP EDGES BURRS, CHIPS, SHAVINGS AND OILS BOTH INTERNALLY AND EXTERNALLY.
5. ALL BEND RADIUS AND RELIEFS TO BE MINIMUM.
6. ALL DIMENSIONS ARE IN MM.
7. UNLESS OTHERWISE SPECIFIED DIMENSIONS REFER DXF DRAWING.

SUPERSEDES:		NAME	DATE/SIGN
MATERIAL:		DRAWN	SUDHAGAR 08.10.2024
WEIGHT: 50.80G	THK: MM	CHK'D	08.10.2024
FINISH: SEE NOTES		APPV'D	BALRAM 08.10.2024
TOLERANCES UNLESS OTHERWISE SPECIFIED		STATUS: REV 04	
LINEAR DIMENSION			
0.5-3	3-6	6-30	30-120
±0.5	±0.5	±1	±2
ANGULAR DIMENSION			
0-10	10-50	50-120	120-400
±1°	±0.30°	±0.30°	±0.10°
EXTERNAL RADII & CH			
0.5 - 3	3 - 6	OVER 6	
±0.2	±0.5	±1	

DOC TYPE: MECHANICAL DRAWING

PRODUCT: 22.5-30 KVA SCVS DM DG

TITLE: SPIKE PLATE ASSY

DWG NO: RCAB00976R5-01-09

SIZE: A3

1:2 23 OF 24