

REVISIONS					
REV	DESCRIPTION	DRN	CHK	APPD	DATE
REV 00					

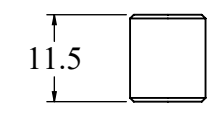

ITEM NO.	PartNo	DESCRIPTION	QTY.
1	RCAB00976R5-01-07_01	CORNER WELD PIECE	1
2	RCAB00976R0-01-07_02	M5 X 11.5 SPACER	1

RE TAPING FOR ALL STUD AFTER POWDER COATING

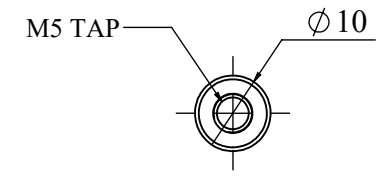
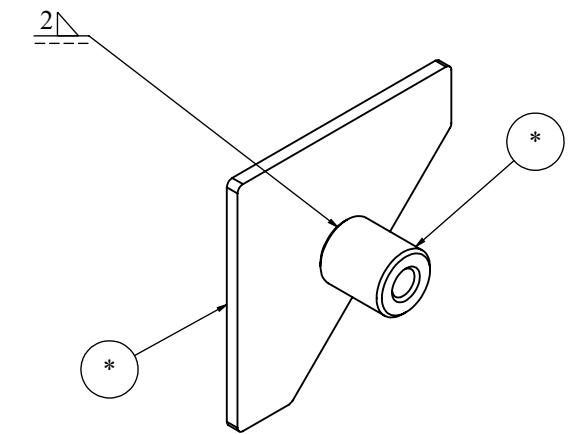
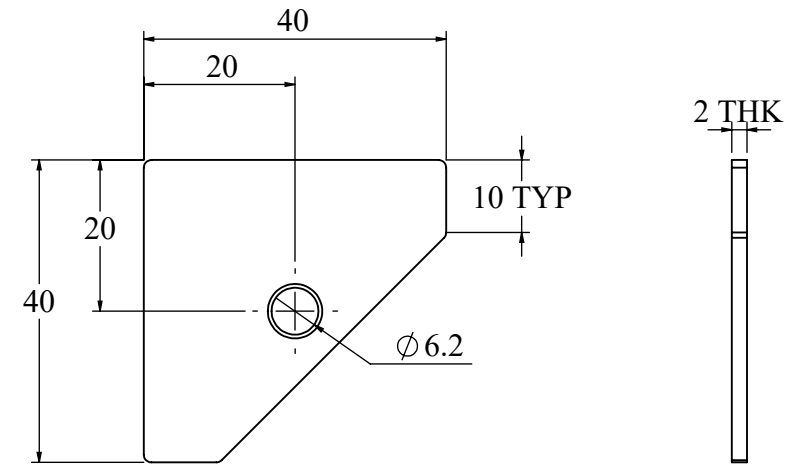

- NOTES - UNLESS OTHERWISE SPECIFIED:
1. FINISH: POWDER COATED - FRAME - 7035, ALL COVERS - 7016 (TEXTURE)
  2. DIMENSIONS ARE TO BE INTERPRETED AS PER ASME Y14.5M - 1994.
  3. ALL DIMENSIONS APPLY AFTER FINISHING.
  4. PART TO BE CLEAN AND FREE OF ALL SHARP EDGES BURRS, CHIPS, SHAVINGS AND OILS BOTH INTERNALLY AND EXTERNALLY.
  5. ALL BEND RADIUS AND RELIEFS TO BE MINIMUM.
  6. ALL DIMENSIONS ARE IN MM.
  7. UNLESS OTHERWISE SPECIFIED DIMENSIONS REFER DXF DRAWING.

SUPERSEDES:		NAME	DATE/SIGN																								
MATERIAL:		DRAWN	SUDHAGAR 08.10.2024																								
WEIGHT: 23.17G	THK: MM	CHK'D																									
FINISH: SEE NOTES		APPV'D	BALRAM																								
TOLERANCES UNLESS OTHERWISE SPECIFIED		STATUS: REV 00																									
<table border="1"> <thead> <tr> <th colspan="8">LINEAR DIMENSION</th> </tr> <tr> <th>0.5-3</th> <th>3-6</th> <th>6-30</th> <th>30-120</th> <th>120-400</th> <th>400-1000</th> <th>1000-2000</th> <th>2000-4000</th> </tr> </thead> <tbody> <tr> <td>±0.5</td> <td>±0.5</td> <td>±1</td> <td>±2</td> <td>±3</td> <td>±4</td> <td>±5</td> <td>±10</td> </tr> </tbody> </table>				LINEAR DIMENSION								0.5-3	3-6	6-30	30-120	120-400	400-1000	1000-2000	2000-4000	±0.5	±0.5	±1	±2	±3	±4	±5	±10
LINEAR DIMENSION																											
0.5-3	3-6	6-30	30-120	120-400	400-1000	1000-2000	2000-4000																				
±0.5	±0.5	±1	±2	±3	±4	±5	±10																				
<table border="1"> <thead> <tr> <th colspan="4">ANGLER DIMENSION</th> <th colspan="4">EXTERNAL RADII &amp; CH</th> </tr> <tr> <th>0-10</th> <th>10-50</th> <th>50-120</th> <th>120-400</th> <th>OVER 400</th> <th>0.5 - 3</th> <th>3 - 6</th> <th>OVER 6</th> </tr> </thead> <tbody> <tr> <td>±1°</td> <td>±0.30°</td> <td>±0.30°</td> <td>±0.10°</td> <td>±0.5°</td> <td>±0.2</td> <td>±0.5</td> <td>±1</td> </tr> </tbody> </table>				ANGLER DIMENSION				EXTERNAL RADII & CH				0-10	10-50	50-120	120-400	OVER 400	0.5 - 3	3 - 6	OVER 6	±1°	±0.30°	±0.30°	±0.10°	±0.5°	±0.2	±0.5	±1
ANGLER DIMENSION				EXTERNAL RADII & CH																							
0-10	10-50	50-120	120-400	OVER 400	0.5 - 3	3 - 6	OVER 6																				
±1°	±0.30°	±0.30°	±0.10°	±0.5°	±0.2	±0.5	±1																				
THIRD ANGLE PROJECTION:																											

DOC TYPE: MECHANICAL DRAWING	
PRODUCT: 22.5-30 KVA SCVS DM DG	
TITLE: CORNER WELD PIECE ASSY	
DWG NO: RCAB00976R0-01-07	SIZE: A3
1:1	18 OF 24