

REVISIONS					
REV	DESCRIPTION	DRN	CHK	APPD	DATE
REV 00					

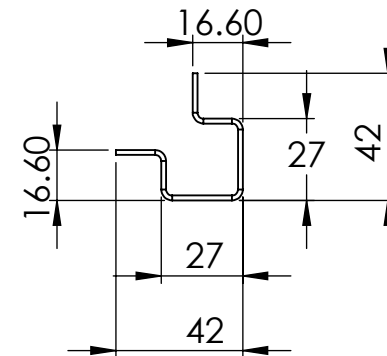

DETAIL A
SCALE 2 : 5

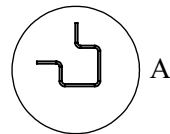
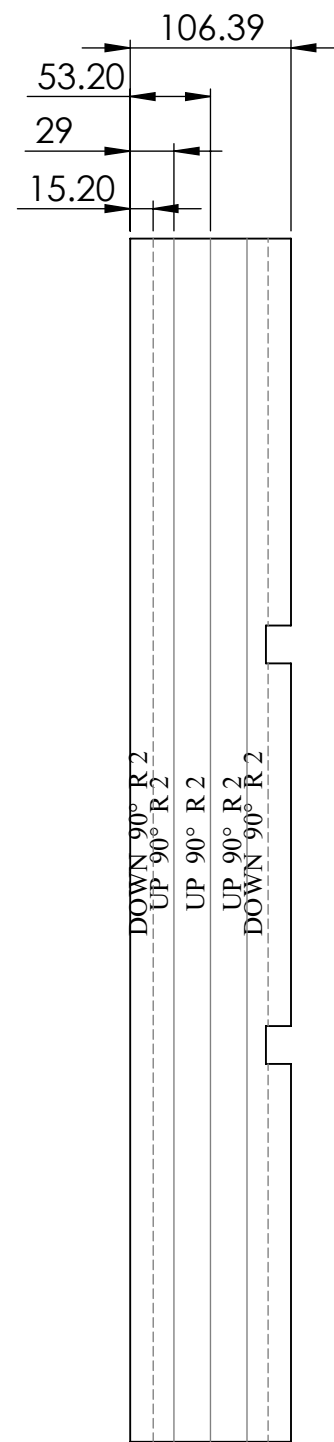
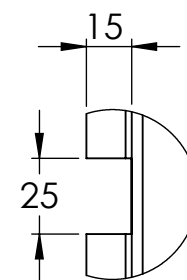

DETAIL B
SCALE 2 : 5

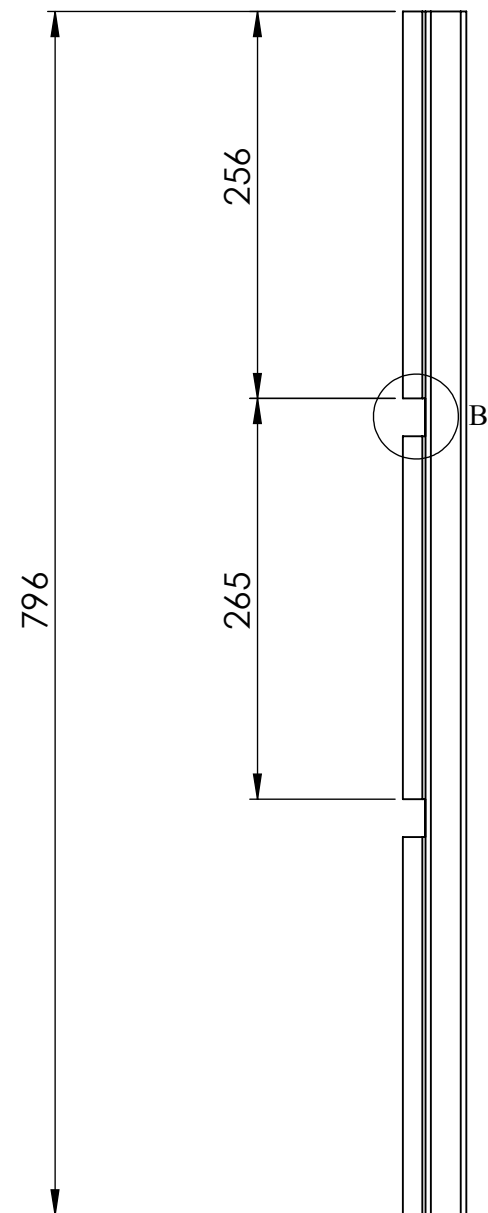

NOTES - UNLESS OTHERWISE SPECIFIED:

1. FINISH: POWDER COATED - FRAME - 7035, ALL COVERS - 7016 (TEXTURE)
2. DIMENSIONS ARE TO BE INTERPRETED AS PER ASME Y14.5M - 1994.
3. ALL DIMENSIONS APPLY AFTER FINISHING.
4. PART TO BE CLEAN AND FREE OF ALL SHARP EDGES BURRS, CHIPS, SHAVINGS AND OILS BOTH INTERNALLY AND EXTERNALLY.
5. ALL BEND RADIUS AND RELIEFS TO BE MINIMUM.
6. ALL DIMENSIONS ARE IN MM.
7. UNLESS OTHERWISE SPECIFIED DIMENSIONS REFER DXF DRAWING.

SUPERSEDES:		NAME	DATE/SIGN	DOC TYPE: MECHANICAL DRAWING																								
MATERIAL: CRCA		DRAWN	SUDHAGAR 02.07.2024																									
WEIGHT: 1053.28G	THK: 1.6MM	CHK'D		PRODUCT: 12-15KVA SCVS DM DG																								
FINISH: SEE NOTES		APPV'D	BALRAM	TITLE: VERTICAL LEG BR																								
TOLERANCES UNLESS OTHERWISE SPECIFIED		STATUS: REV 00		DWG NO: RCAB00958R0-01-00_03																								
<table border="1"> <thead> <tr> <th colspan="8">LINEAR DIMENSION</th> </tr> <tr> <th>0.5-3</th> <th>3-6</th> <th>6-30</th> <th>30-120</th> <th>120-400</th> <th>400-1000</th> <th>1000-2000</th> <th>2000-4000</th> </tr> </thead> <tbody> <tr> <td>±0.5</td> <td>±0.5</td> <td>±1</td> <td>±2</td> <td>±3</td> <td>±4</td> <td>±5</td> <td>±10</td> </tr> </tbody> </table>		LINEAR DIMENSION								0.5-3	3-6	6-30	30-120	120-400	400-1000	1000-2000	2000-4000	±0.5	±0.5	±1	±2	±3	±4	±5	±10	THIRD ANGLE PROJECTION:		SIZE: A3
LINEAR DIMENSION																												
0.5-3	3-6	6-30	30-120	120-400	400-1000	1000-2000	2000-4000																					
±0.5	±0.5	±1	±2	±3	±4	±5	±10																					
<table border="1"> <thead> <tr> <th colspan="4">ANGLER DIMENSION</th> <th colspan="3">EXTERNAL RADII & CH</th> </tr> <tr> <th>0-10</th> <th>10-50</th> <th>50-120</th> <th>120-400</th> <th>OVER 400</th> <th>0.5 - 3</th> <th>3 - 6</th> <th>OVER 6</th> </tr> </thead> <tbody> <tr> <td>±1°</td> <td>±0.30°</td> <td>±0.30°</td> <td>±0.10°</td> <td>±0.5°</td> <td>±0.2</td> <td>±0.5</td> <td>±1</td> </tr> </tbody> </table>		ANGLER DIMENSION				EXTERNAL RADII & CH			0-10	10-50	50-120	120-400	OVER 400	0.5 - 3	3 - 6	OVER 6	±1°	±0.30°	±0.30°	±0.10°	±0.5°	±0.2	±0.5	±1	1:5		7 OF 28	
ANGLER DIMENSION				EXTERNAL RADII & CH																								
0-10	10-50	50-120	120-400	OVER 400	0.5 - 3	3 - 6	OVER 6																					
±1°	±0.30°	±0.30°	±0.10°	±0.5°	±0.2	±0.5	±1																					

