

REVISIONS					
REV	DESCRIPTION	DRN	CHK	APPD	DATE
REV 05					

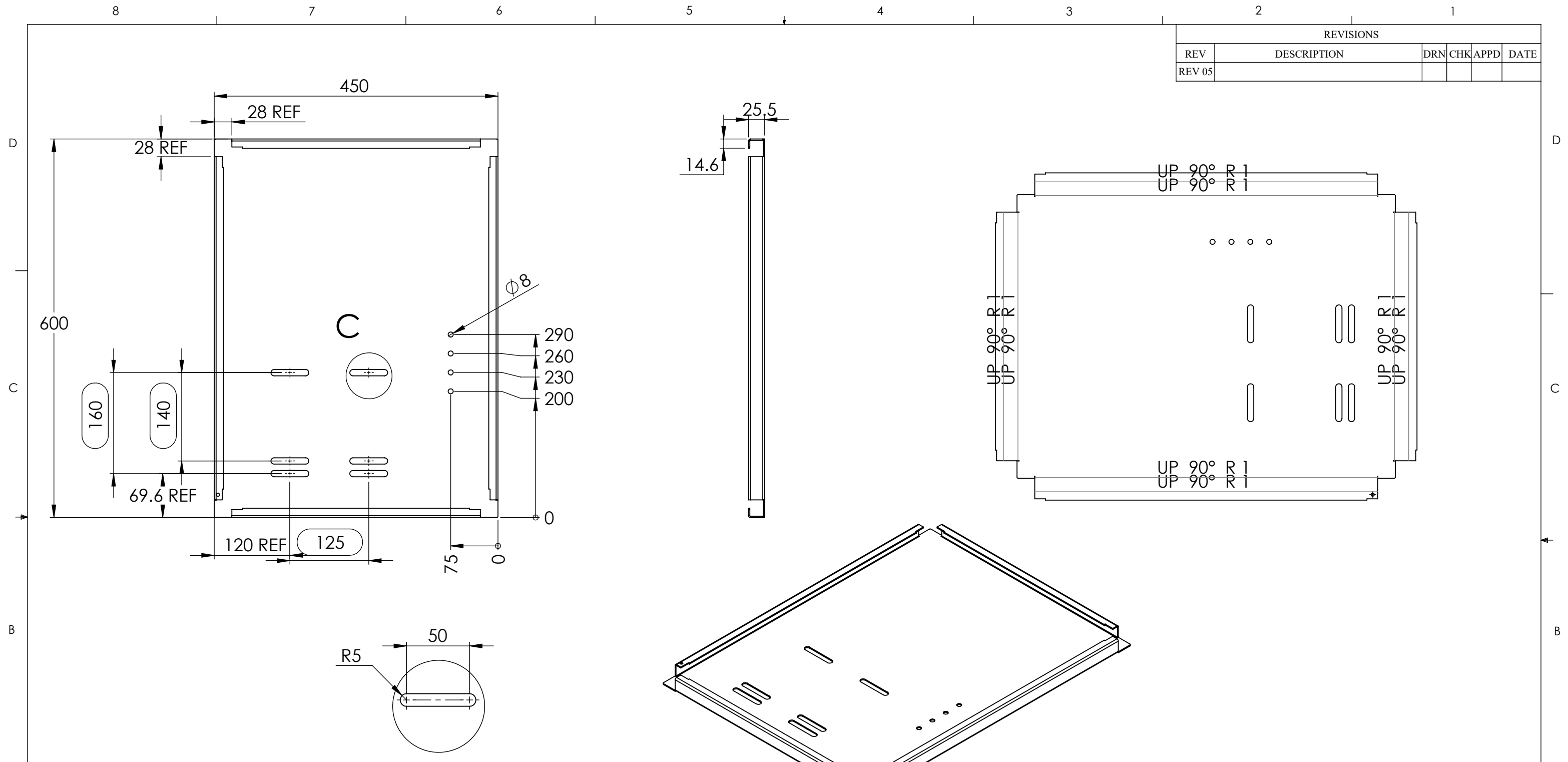

DETAIL C  
SCALE 1 : 3

- NOTES - UNLESS OTHERWISE SPECIFIED:
1. FINISH: POWDER COATED - FRAME - 7035, ALL COVERS - 7016 (TEXTURE)
  2. DIMENSIONS ARE TO BE INTERPRETED AS PER ASME Y14.5M - 1994.
  3. ALL DIMENSIONS APPLY AFTER FINISHING.
  4. PART TO BE CLEAN AND FREE OF ALL SHARP EDGES BURRS, CHIPS, SHAVINGS AND OILS BOTH INTERNALLY AND EXTERNALLY.
  5. ALL BEND RADIUS AND RELIEFS TO BE MINIMUM.
  6. ALL DIMENSIONS ARE IN MM.
  7. UNLESS OTHERWISE SPECIFIED DIMENSIONS REFER DXF DRAWING.

SUPERSEDES:		NAME	DATE/SIGN
MATERIAL: CRCA		DRAWN	SUDHAGAR 08.10.2024
WEIGHT: 0.01G	THK: 2MM	CHK'D	
FINISH: SEE NOTES		APPV'D	BALRAM
TOLERANCES UNLESS OTHERWISE SPECIFIED		STATUS: REV 05	
LINEAR DIMENSION			
0.5-3	3-6	6-30	30-120
±0.5	±0.5	±1	±2
120-400		400-1000	
±3		±4	
1000-2000		2000-4000	
±5		±10	
ANGULAR DIMENSION			
EXTERNAL RADII & CH			
0-10	10-50	50-120	120-400
±1°	±0.30°	±0.30°	±0.10°
OVER 400		OVER 6	
±0.5°		±0.2	
±0.2		±0.5	
±0.5		±1	
THIRD ANGLE PROJECTION:			

**Fuji Electric**

DOC TYPE: MECHANICAL DRAWING

PRODUCT: 22.5-30KVA SCVS DM DG

TITLE: BASE PLATE

DWG NO: RCAB00976R5

SIZE: A3

1:6 2 OF 5