

REVISIONS					
REV	DESCRIPTION	DRN	CHK	APPD	DATE
REV 01	MCCB CUP	AJ	--	AK	25.03.19

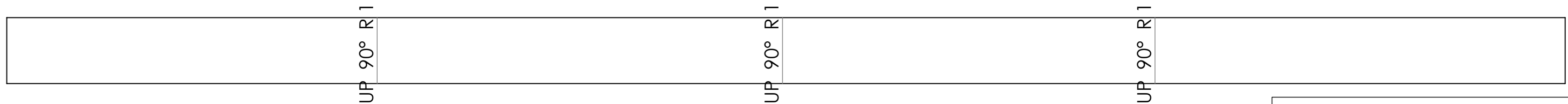
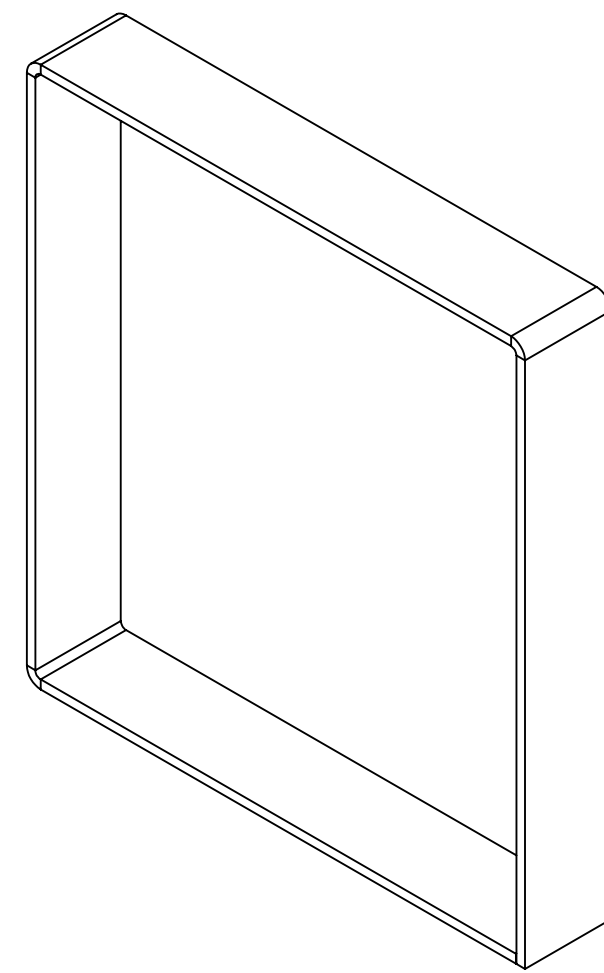
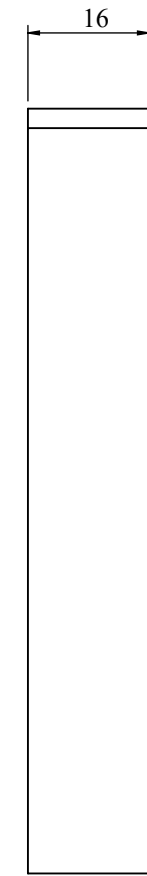
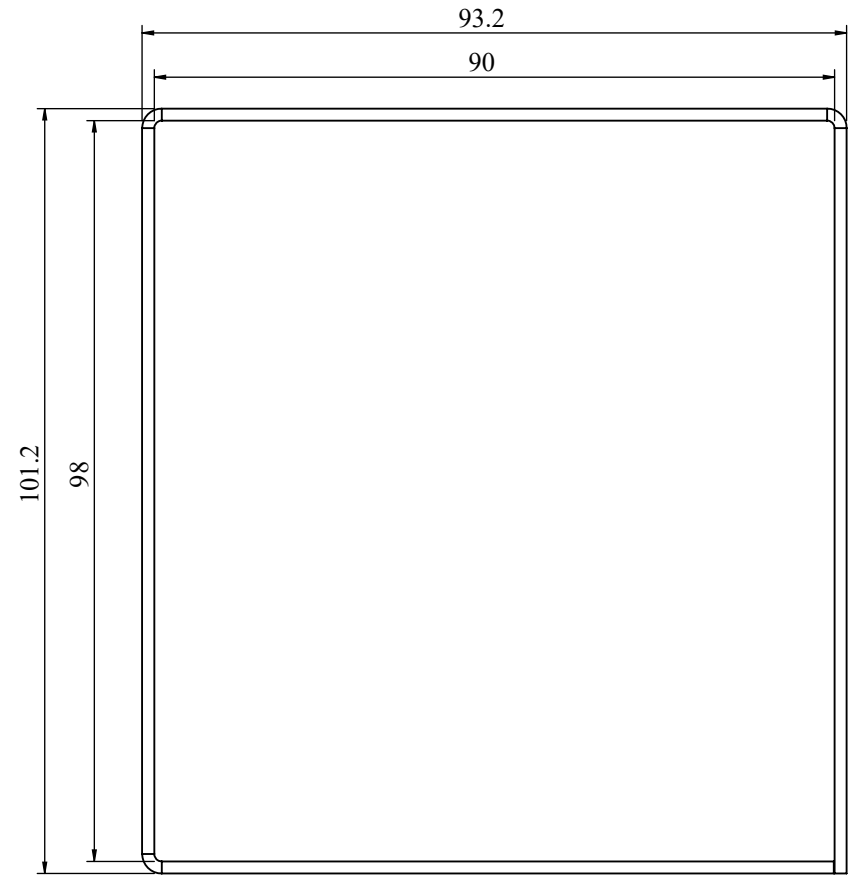

UP 90° R1

UP 90° R1

UP 90° R1



NOTES - UNLESS OTHERWISE SPECIFIED:

1. FINISH: POWDER COATED - FRAME - 7035, ALL COVERS - 7016 (TEXTURE)
2. DIMENSIONS ARE TO BE INTERPRETED AS PER ASME Y14.5M - 1994.
3. ALL DIMENSIONS APPLY AFTER FINISHING.
4. PART TO BE CLEAN AND FREE OF ALL SHARP EDGES BURRS, CHIPS, SHAVINGS AND OILS BOTH INTERNALLY AND EXTERNALLY.
5. ALL BEND RADIUS AND RELIEFS TO BE MINIMUM.
6. ALL DIMENSIONS ARE IN MM.
7. UNLESS OTHERWISE SPECIFIED DIMENSIONS REFER DXF DRAWING.

SUPERSEDES:		NAME	DATE/SIGN
MATERIAL: CRCA		DRAWN	SUDHAGAR 08.10.2024
WEIGHT: 76.36G	THK: 1.6MM	CHK'D	
FINISH: SEE NOTES		APPV'D	BALRAM
TOLERANCES UNLESS OTHERWISE SPECIFIED		STATUS: REV 01	
LINEAR DIMENSION			
0.5-3	3-6	6-30	30-120
120-400	400-1000	1000-2000	2000-4000
±0.5	±0.5	±1	±2
±3	±4	±5	±10
ANGLER DIMENSION		EXTERNAL RADII & CH	
0-10	10-50	50-120	120-400
OVER 400	0.5 - 3	3 - 6	OVER 6
±1°	±0.30°	±0.30°	±0.10°
±0.5°	±0.2	±0.5	±1

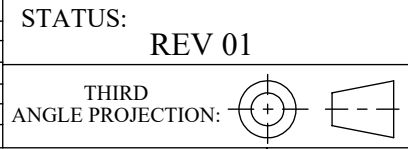

DOC TYPE: MECHANICAL DRAWING	
PRODUCT: 22.5-30KVA SCVS DM DG	
TITLE: MCCB WELD CUP	
DWG NO: RCAB00976R1-04_06	SIZE: A3
1:1	4 OF 5