

REVISIONS					
REV	DESCRIPTION	DRN	CHK	APPD	DATE
REV 05					

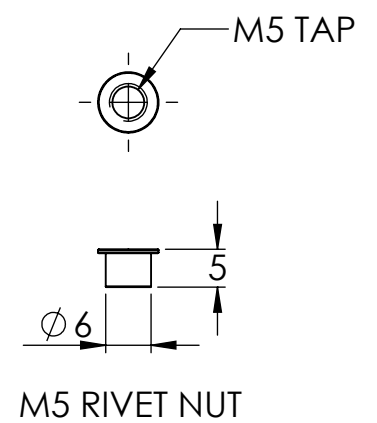

DETAIL F
SCALE 2 : 5

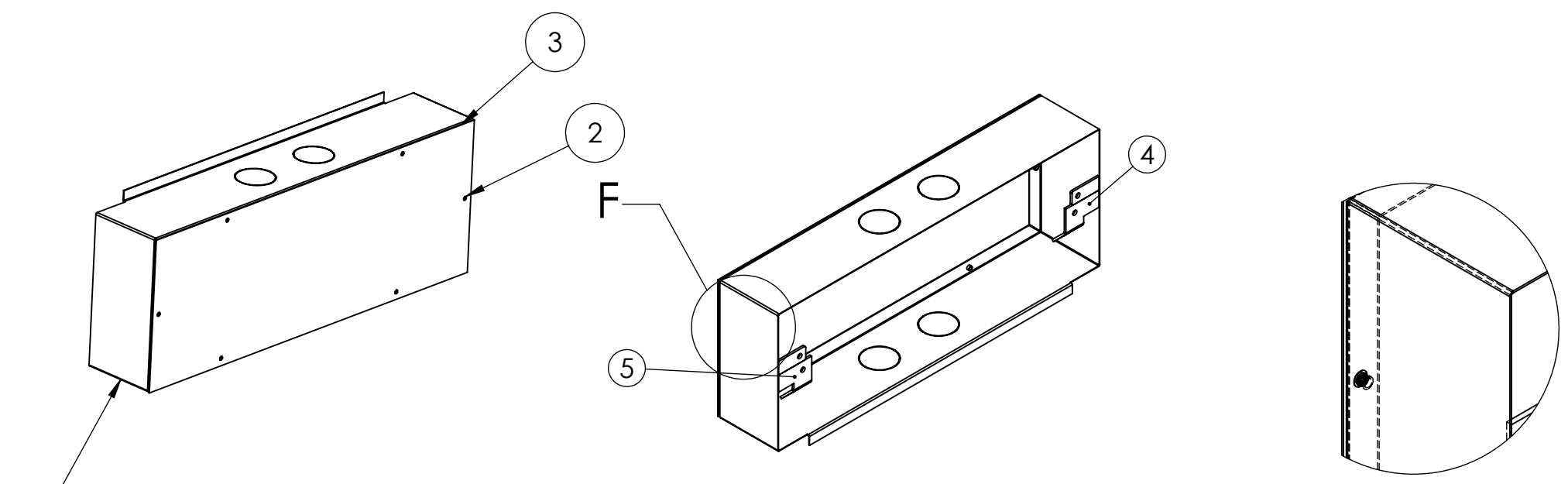
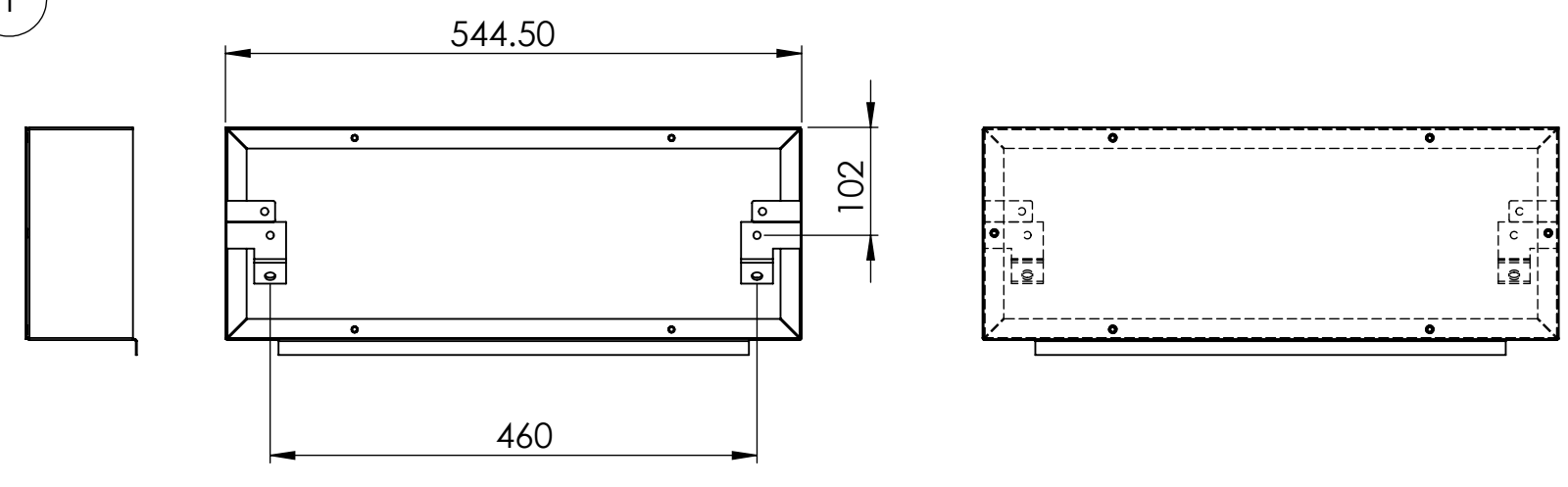

ITEM NO.	PART NO	DESCRIPTION	QTY.
1	RCAB00976R0-08_01	TERMINAL BOX	1
2	RCAB00976R0-08_02	RIVIT NUT	6
3	RCAB00976R0-08_03	TERMINAL COVER	1
4	RCAB00976R1-08_04	TERMINAL CLAMP	1
5	RCAB00976R1-08_05	TERMINAL CLAMP	1
6	RCAB00976R0-08_06	TERMINAL BOX CLAMP	2

NOTES - UNLESS OTHERWISE SPECIFIED:

1. FINISH: POWDER COATED - FRAME - 7035, ALL COVERS - 7016 (TEXTURE)
2. DIMENSIONS ARE TO BE INTERPRETED AS PER ASME Y14.5M - 1994.
3. ALL DIMENSIONS APPLY AFTER FINISHING.
4. PART TO BE CLEAN AND FREE OF ALL SHARP EDGES BURRS, CHIPS, SHAVINGS AND OILS BOTH INTERNALLY AND EXTERNALLY.
5. ALL BEND RADIUS AND RELIEFS TO BE MINIMUM.
6. ALL DIMENSIONS ARE IN MM.
7. UNLESS OTHERWISE SPECIFIED DIMENSIONS REFER DXF DRAWING.

SUPERSEDES:		NAME	DATE/SIGN
MATERIAL:		DRAWN	SUDHAGAR 08.10.2024
WEIGHT: 2434.32G	THK: MM	CHK'D	
FINISH: SEE NOTES		APPV'D	BALRAM
TOLERANCES UNLESS OTHERWISE SPECIFIED		STATUS: REV 05	
LINEAR DIMENSION			
0.5-3	3-6	6-30	30-120
120-400	400-1000	1000-2000	2000-4000
±0.5	±0.5	±1	±2
±3	±4	±5	±10
ANGULAR DIMENSION		EXTERNAL RADII & CH	
0-10	10-50	50-120	120-400
OVER 400	0.5 - 3	3 - 6	OVER 6
±1°	±0.30°	±0.30°	±0.10°
±0.5°	±0.2	±0.5	±1
THIRD ANGLE PROJECTION:			

DOC TYPE: MECHANICAL DRAWING

PRODUCT: 22.5-30KVA SCVS DM DG

TITLE: TERMINAL BOX ASSY

DWG NO: RCAB00976R5

SIZE: A3

1:7 1 OF 6