

REVISIONS					
REV	DESCRIPTION	DRN	CHK	APPD	DATE
REV 01	HOLE SIZE	AJ		AK	21.12.19

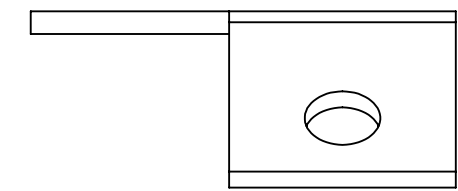
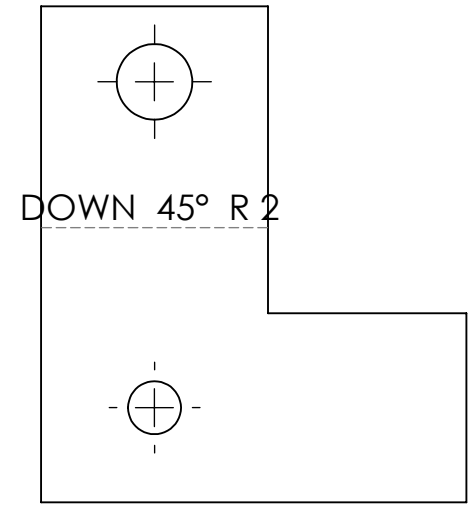
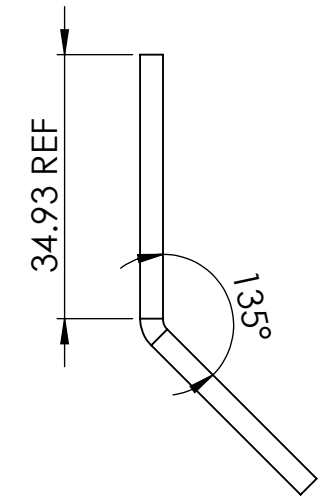
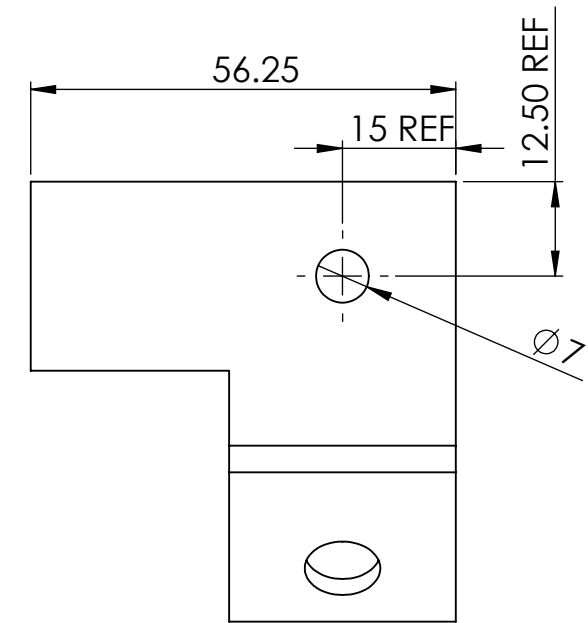
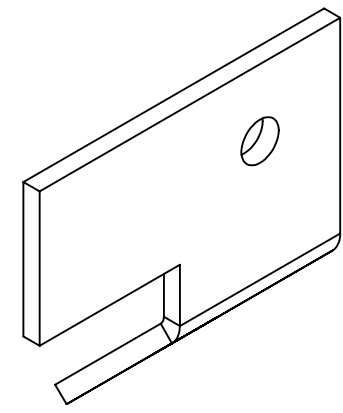

NOTES - UNLESS OTHERWISE SPECIFIED:

1. FINISH: POWDER COATED - FRAME - 7035, ALL COVERS - 7016 (TEXTURE)
2. DIMENSIONS ARE TO BE INTERPRETED AS PER ASME Y14.5M - 1994.
3. ALL DIMENSIONS APPLY AFTER FINISHING.
4. PART TO BE CLEAN AND FREE OF ALL SHARP EDGES BURRS, CHIPS, SHAVINGS AND OILS BOTH INTERNALLY AND EXTERNALLY.
5. ALL BEND RADIUS AND RELIEFS TO BE MINIMUM.
6. ALL DIMENSIONS ARE IN MM.
7. UNLESS OTHERWISE SPECIFIED DIMENSIONS REFER DXF DRAWING.

SUPERSEDES:		NAME	DATE/SIGN
MATERIAL: CRCA		DRAWN	SUDHAGAR 08.10.2024
WEIGHT: 59.05G	THK: 3MM	CHK'D	
FINISH: SEE NOTES		APPV'D	BALRAM
TOLERANCES UNLESS OTHERWISE SPECIFIED		STATUS: REV 01	
LINEAR DIMENSION			
0.5-3	3-6	6-30	30-120
±0.5	±0.5	±1	±2
ANGULAR DIMENSION			
0-10	10-50	50-120	120-400
±1°	±0.30°	±0.30°	±0.10°
EXTERNAL RADII & CH			
0.5 - 3	3 - 6	OVER 6	
±0.2	±0.5	±1	



DOC TYPE: MECHANICAL DRAWING	
PRODUCT: 22.5-30KVA SCVS DM DG	
TITLE: TERMINAL CLAMP	
DWG NO: RCAB00976R1-08_05	SIZE: A3
1:1	4 OF 6