

REVISIONS					
REV	DESCRIPTION	DRN	CHK	APPD	DATE

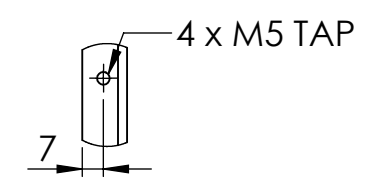
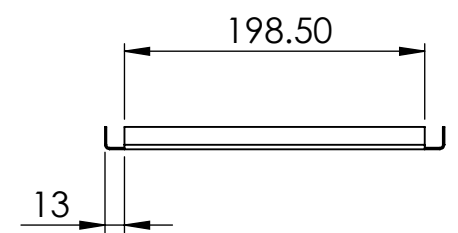
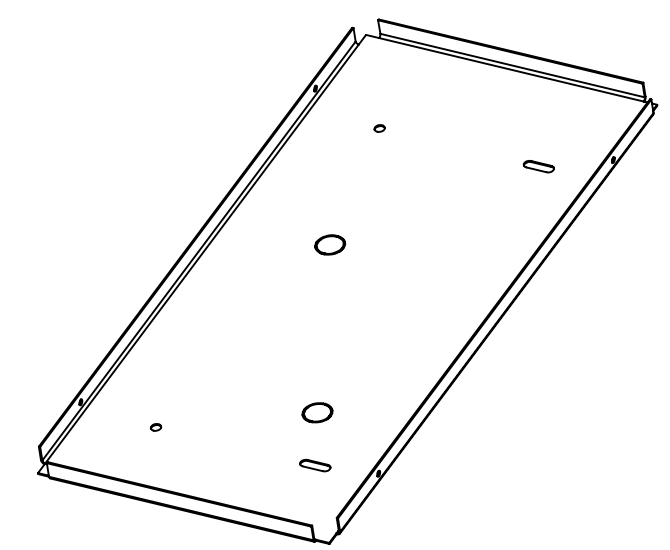
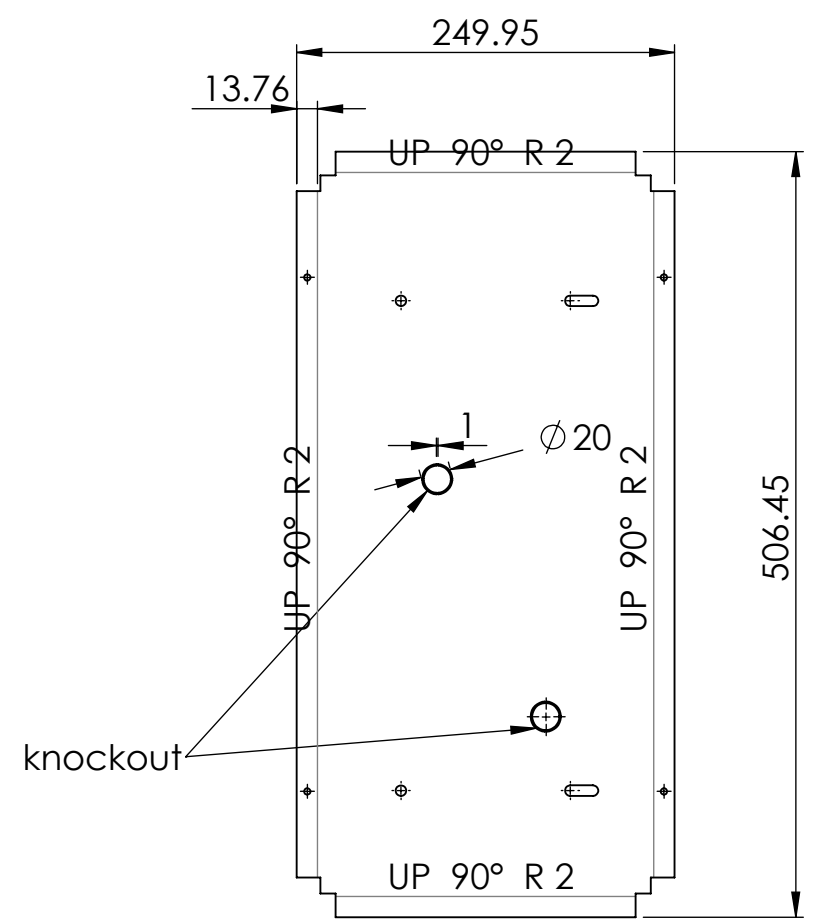
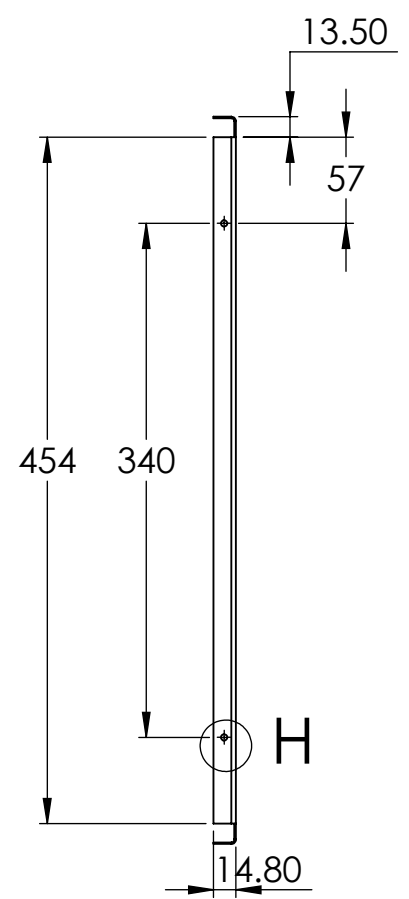
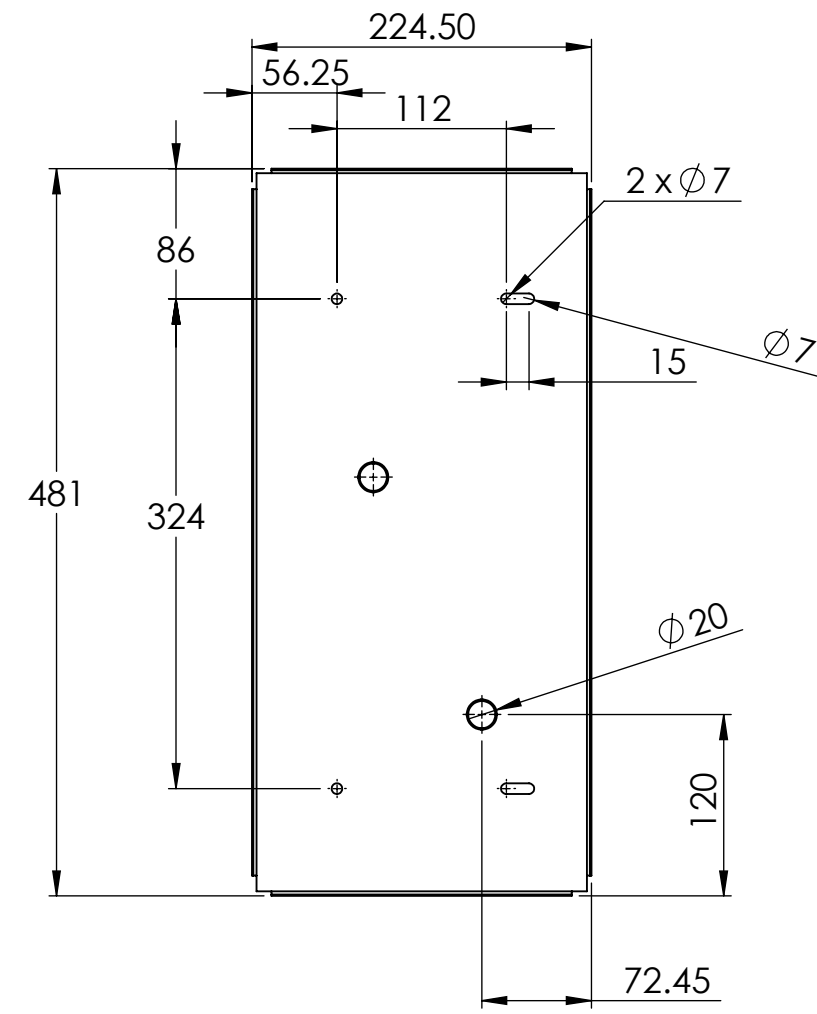

DETAIL H
SCALE 2 : 5

- NOTES - UNLESS OTHERWISE SPECIFIED:
1. FINISH: POWDER COATED - RAL9005 - BLACK (MATT FINISH)
 2. DIMENSIONS ARE TO BE INTERPRETED AS PER ASME Y14.5M - 1994.
 3. ALL DIMENSIONS APPLY AFTER FINISHING.
 4. PART TO BE CLEAN AND FREE OF ALL SHARP EDGES BURRS, CHIPS, SHAVINGS AND OILS BOTH INTERNALLY AND EXTERNALLY.
 5. ALL BEND RADIUS AND RELIEFS TO BE MINIMUM.
 6. ALL DIMENSIONS ARE IN MM.
 7. UNLESS OTHERWISE SPECIFIED DIMENSIONS REFER DXF DRAWING.

SUPERSEDES:		NAME	DATE/SIGN
MATERIAL: CRCA 1.2mm THK		DRAWN	MA
WEIGHT: G	THK: MM	CHK'D	VK
FINISH: SEE NOTES		APPV'D	ASK
TOLERANCES UNLESS OTHERWISE SPECIFIED		STATUS:	
LINEAR DIMENSION			
0.5-3	3-6	6-30	30-120
±0.5	±0.5	±1	±2
ANGULAR DIMENSION			
0-10	10-50	50-120	120-400
±1°	±0.30°	±0.30°	±0.10°
EXTERNAL RADII & CH			
0.5 - 3	3 - 6	OVER 6	
±0.2	±0.5	±1	

FE Fuji Electric

DOC TYPE: MECHANICAL DRAWING

PRODUCT: 15-20 A M.S. STAND

TITLE: RCAB00094R0-01-00_02

DWG NO: 1:10

6 OF 8

SIZE: A3