

REVISIONS					
REV	DESCRIPTION	DRN	CHK	APPD	DATE
REV 00	REAR CUTOUT	AJ			08.01.2019

ITEM NO.	PART NO	DESCRIPTION	QTY.
1	RCAB03622R1-01-03_01	REAR PART	1
2	RCAB01914R0-01-03_02	M4 STUD / WELD NUT	8

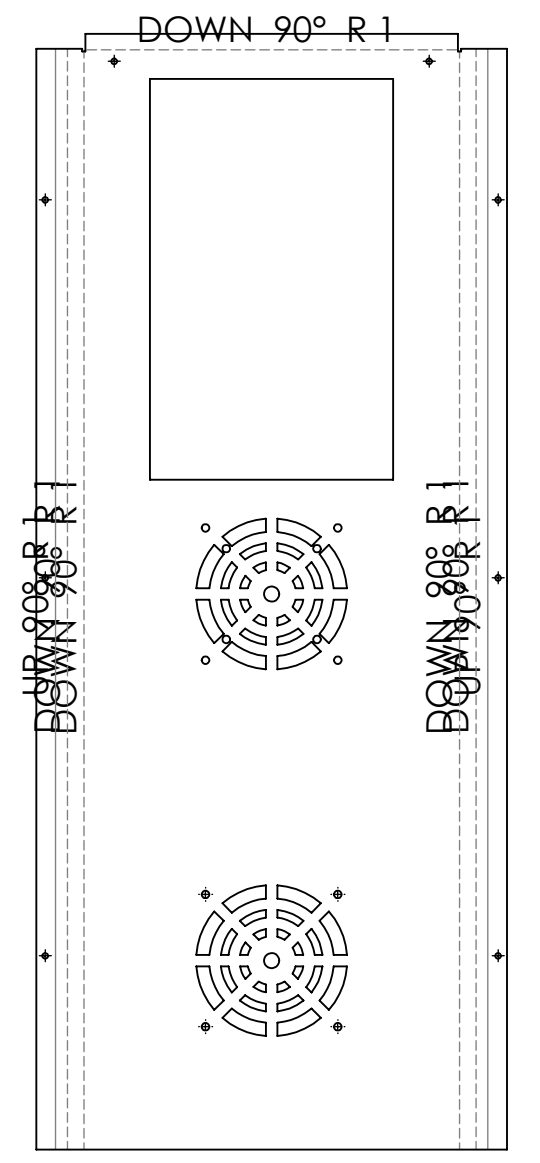
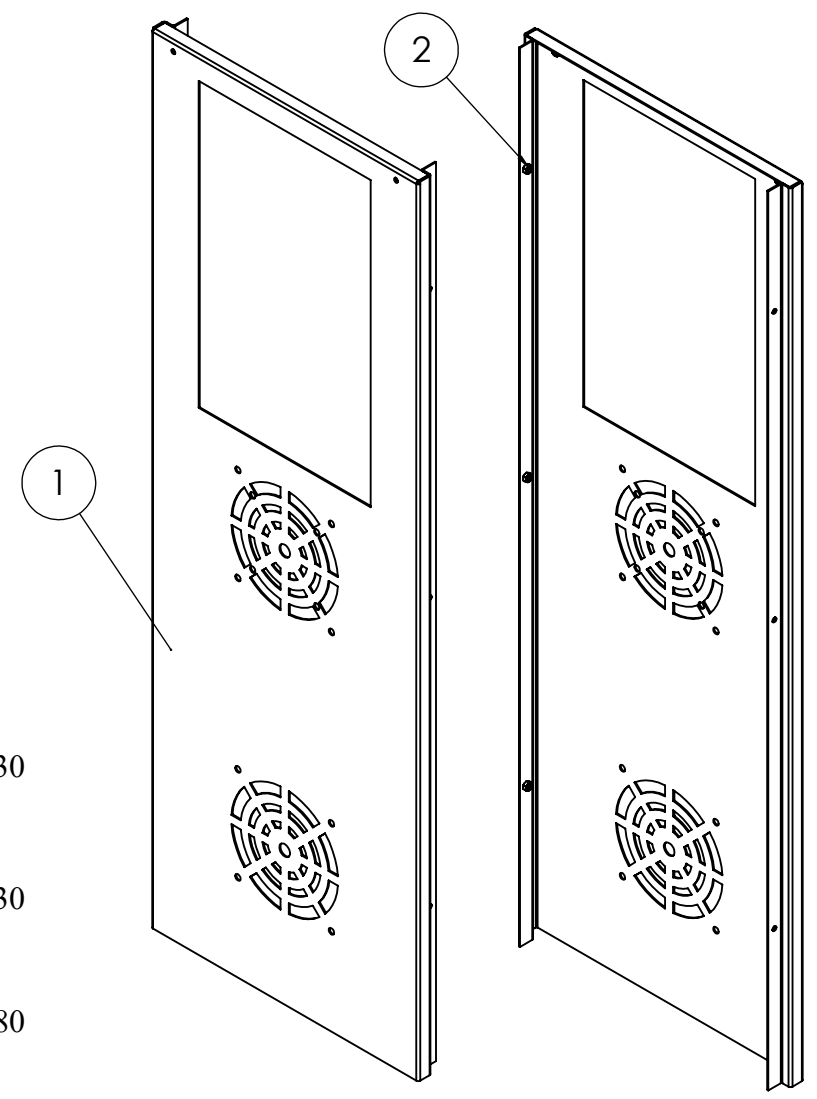
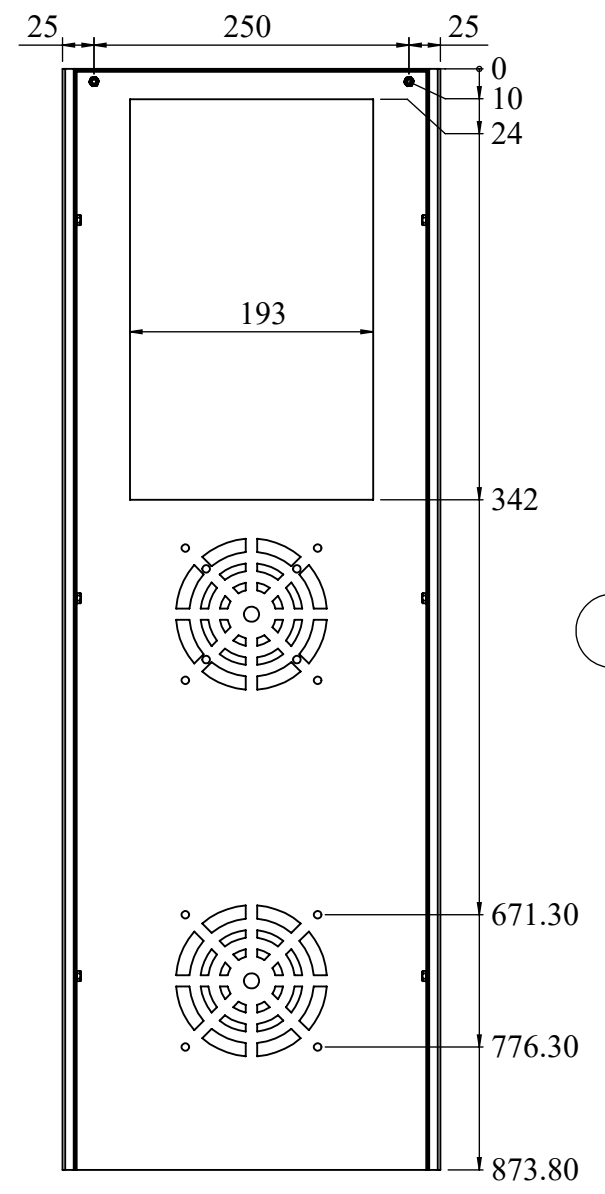
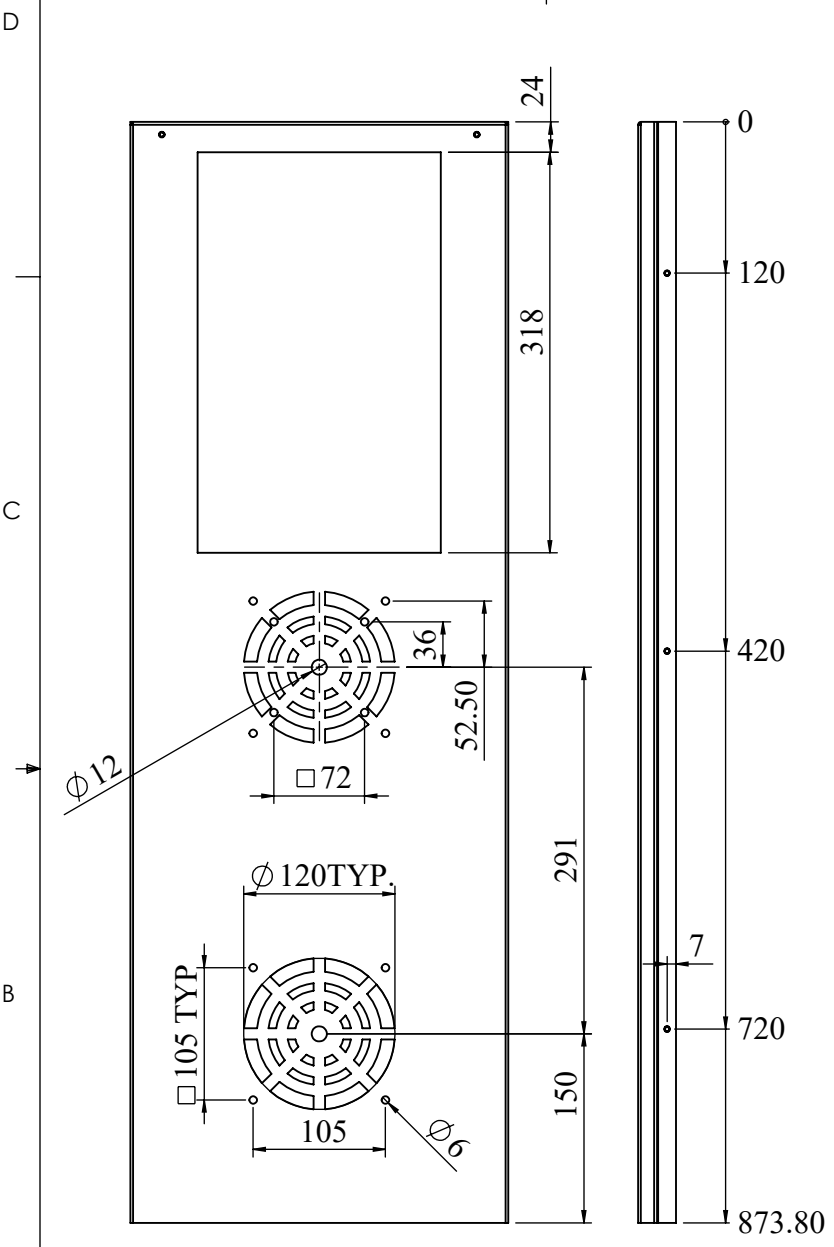
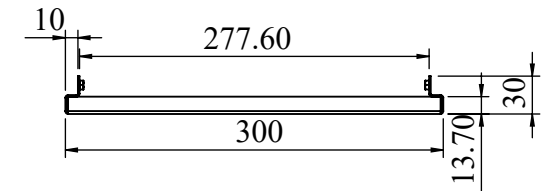

- NOTES - UNLESS OTHERWISE SPECIFIED:
1. FINISH: POWDER COATED - RAL9005 - BLACK (MATT FINISH)
 2. DIMENSIONS ARE TO BE INTERPRETED AS PER ASME Y14.5M - 1994.
 3. ALL DIMENSIONS APPLY AFTER FINISHING.
 4. PART TO BE CLEAN AND FREE OF ALL SHARP EDGES BURRS, CHIPS, SHAVINGS AND OILS BOTH INTERNALLY AND EXTERNALLY.
 5. ALL BEND RADIUS AND RELIEFS TO BE MINIMUM.
 6. ALL DIMENSIONS ARE IN MM.
 7. UNLESS OTHERWISE SPECIFIED DIMENSIONS REFER DXF DRAWING.

SUPERSEDES:		NAME	DATE/SIGN
MATERIAL: CRCA		DRAWN	VIGNESH 07-09-2020
WEIGHT: 2443.11G	THK: 1.2MM	CHK'D	VS
FINISH: SEE NOTES		APPV'D	AK
TOLERANCES UNLESS OTHERWISE SPECIFIED		STATUS: REV 00	
LINEAR DIMENSION			
0.5-3	3-6	6-30	30-120
±0.5	±0.5	±1	±2
ANGULAR DIMENSION			
0-10	10-50	50-120	120-400
±1°	±0.30°	±0.30°	±0.10°
EXTERNAL RADII & CH			
0.5 - 3	3 - 6	OVER 6	
±0.2	±0.5	±1	

DOC TYPE: MECHANICAL DRAWING	
PRODUCT: 10KVA UPS	
TITLE: REAR PART ASSY	
DWG NO: RCAB03622-R0-01-03	SIZE: A3
1:6	7 OF 14