

REVISIONS					
REV	DESCRIPTION	DRN	CHK	APPD	DATE
REV 01					

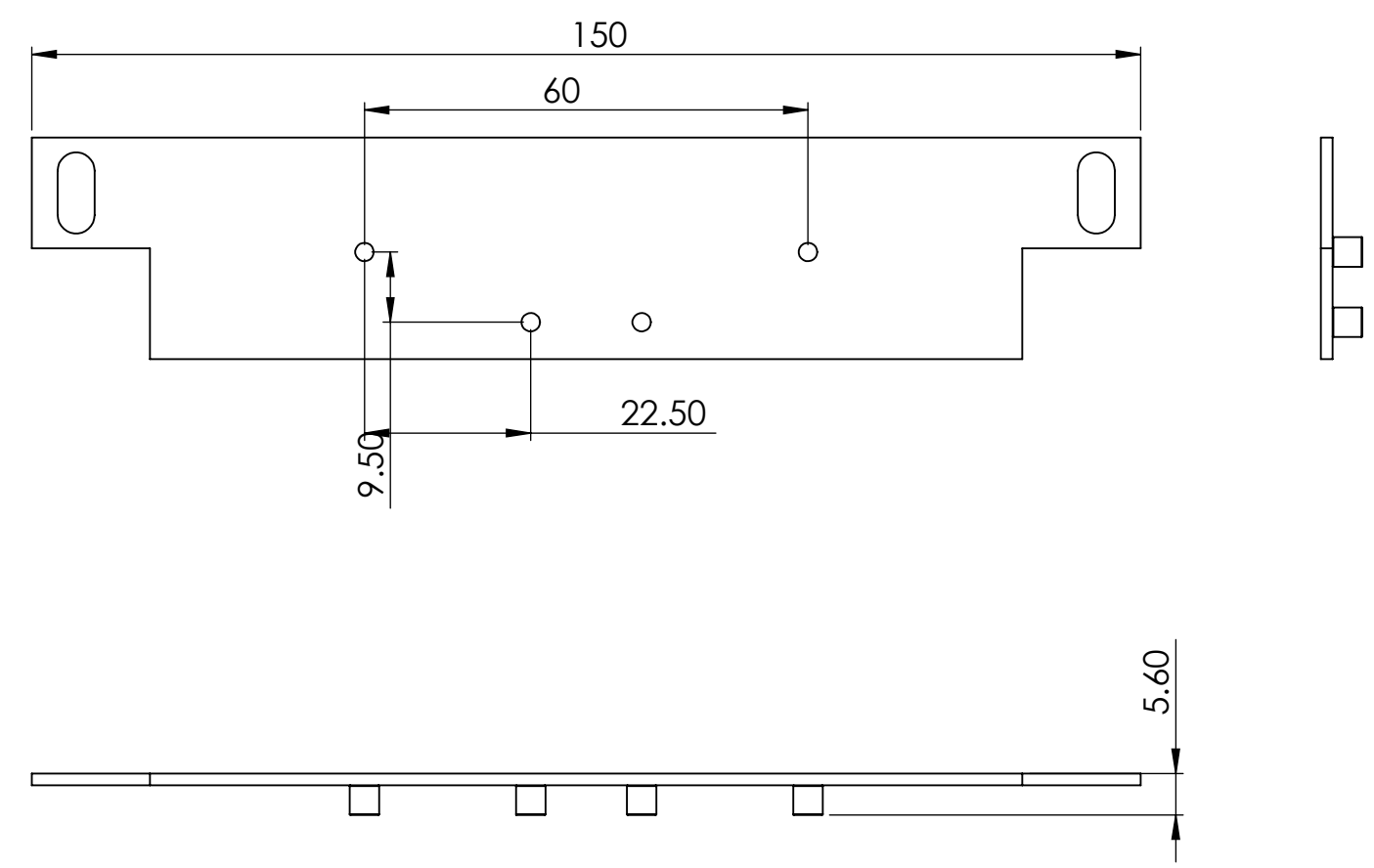
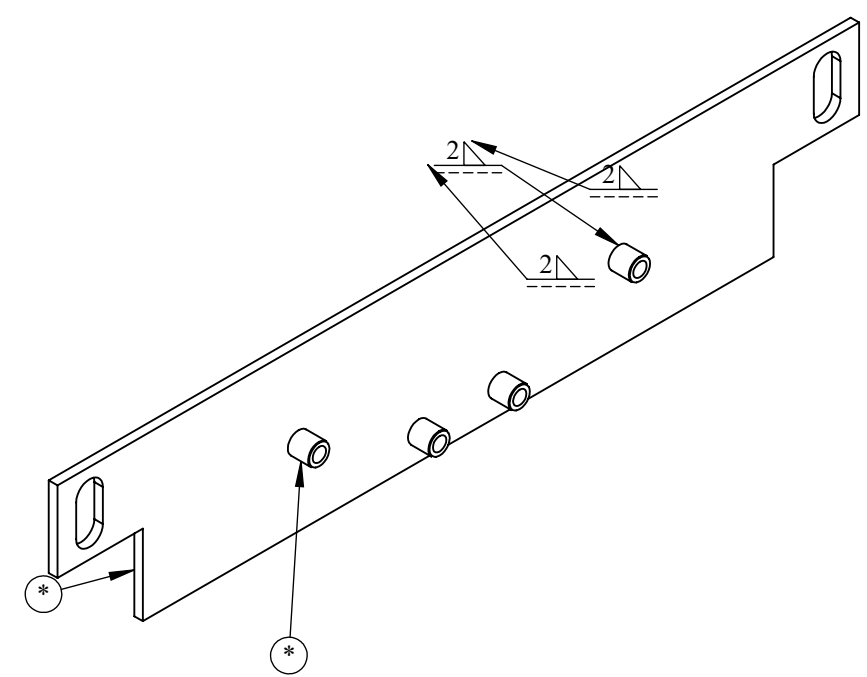

ITEM NO.	PARTNO	DESCRIPTION	QTY.	Revision
1	RCAB00958R1-01-06_01	SMC PLATE	1	REV 01
2	RCAB00958R0-01-06_02	SMC PLATE NUT	4	REV 00

NOTES - UNLESS OTHERWISE SPECIFIED:

1. FINISH: POWDER COATED - FRAME - 7035, ALL COVERS - 7016 (TEXTURE)
2. DIMENSIONS ARE TO BE INTERPRETED AS PER ASME Y14.5M - 1994.
3. ALL DIMENSIONS APPLY AFTER FINISHING.
4. PART TO BE CLEAN AND FREE OF ALL SHARP EDGES BURRS, CHIPS, SHAVINGS AND OILS BOTH INTERNALLY AND EXTERNALLY.
5. ALL BEND RADIUS AND RELIEFS TO BE MINIMUM.
6. ALL DIMENSIONS ARE IN MM.
7. UNLESS OTHERWISE SPECIFIED DIMENSIONS REFER DXF DRAWING.

SUPERSEDES:		NAME	DATE/SIGN																								
MATERIAL:		DRAWN	SUDHAGAR 02.07.2024																								
WEIGHT: 49.96G	THK: MM	CHK'D																									
FINISH: SEE NOTES		APPV'D	BALRAM																								
TOLERANCES UNLESS OTHERWISE SPECIFIED		STATUS: REV 01																									
<table border="1"> <thead> <tr> <th colspan="8">LINEAR DIMENSION</th> </tr> <tr> <th>0.5-3</th> <th>3-6</th> <th>6-30</th> <th>30-120</th> <th>120-400</th> <th>400-1000</th> <th>1000-2000</th> <th>2000-4000</th> </tr> </thead> <tbody> <tr> <td>±0.5</td> <td>±0.5</td> <td>±1</td> <td>±2</td> <td>±3</td> <td>±4</td> <td>±5</td> <td>±10</td> </tr> </tbody> </table>				LINEAR DIMENSION								0.5-3	3-6	6-30	30-120	120-400	400-1000	1000-2000	2000-4000	±0.5	±0.5	±1	±2	±3	±4	±5	±10
LINEAR DIMENSION																											
0.5-3	3-6	6-30	30-120	120-400	400-1000	1000-2000	2000-4000																				
±0.5	±0.5	±1	±2	±3	±4	±5	±10																				
<table border="1"> <thead> <tr> <th colspan="4">ANGLER DIMENSION</th> <th colspan="4">EXTERNAL RADII & CH</th> </tr> <tr> <th>0-10</th> <th>10-50</th> <th>50-120</th> <th>120-400</th> <th>OVER 400</th> <th>0.5 - 3</th> <th>3 - 6</th> <th>OVER 6</th> </tr> </thead> <tbody> <tr> <td>±1°</td> <td>±0.30°</td> <td>±0.30°</td> <td>±0.10°</td> <td>±0.5°</td> <td>±0.2</td> <td>±0.5</td> <td>±1</td> </tr> </tbody> </table>				ANGLER DIMENSION				EXTERNAL RADII & CH				0-10	10-50	50-120	120-400	OVER 400	0.5 - 3	3 - 6	OVER 6	±1°	±0.30°	±0.30°	±0.10°	±0.5°	±0.2	±0.5	±1
ANGLER DIMENSION				EXTERNAL RADII & CH																							
0-10	10-50	50-120	120-400	OVER 400	0.5 - 3	3 - 6	OVER 6																				
±1°	±0.30°	±0.30°	±0.10°	±0.5°	±0.2	±0.5	±1																				
THIRD ANGLE PROJECTION:																											

Fuji Electric

DOC TYPE: MECHANICAL DRAWING

PRODUCT: 12-15KVA SCVS DM DG

TITLE: SMC PLATE ASSY

DWG NO: RCAB00958R1-01-06

SIZE: A3

1:1 24 OF 28